

MS38D2-64H Users Guide

Susei Electronics System Co., Ltd

5th Edition Issued June 2011

1. General Description

MS38D2-64H is a writing target board for standard serial I/O mode used by connecting to EFP-I/1M or EFP-S2/S2V.

Reading and writing data to microcomputer 38D2 groups with built-in Renesas Electronics 8 bit QzROM and Flash is enabled by using MS38D2-64H.

IC socket for 64-pin 0.5mm pitch QFP (PLQP0064KB-A) (64P6Q-A) is mounted on MS38D2-64H.

<Packing contents>

- 1) MS38D2-64H
- 2) Power supply cable for J3
- 3) Users guide (this manual)

External Figure of MS38D2-64H is shown in Fig 1.1.

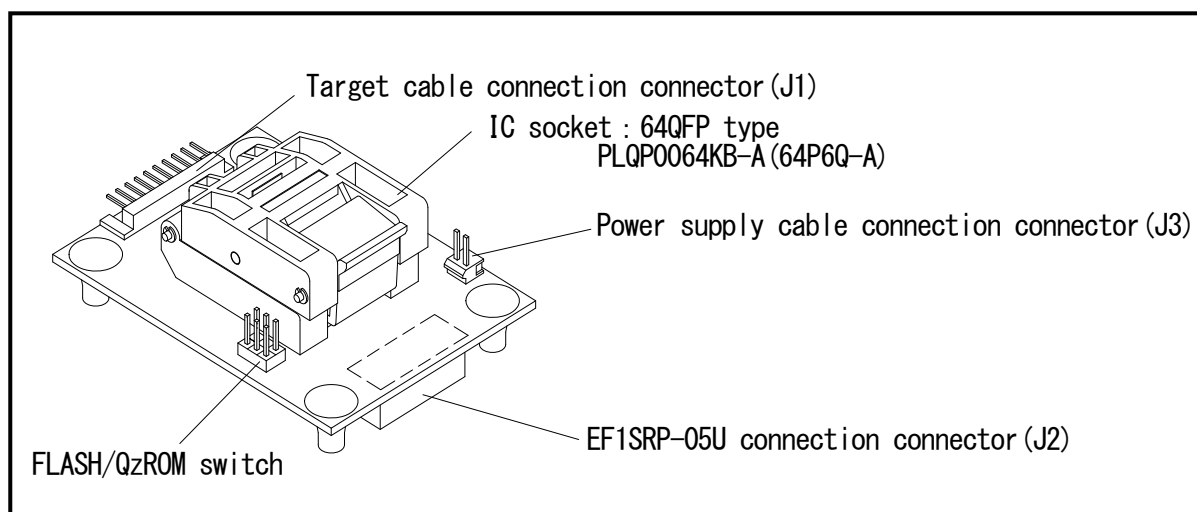

Fig 1.1 MS38D2-64H External Figure

2. Device constitution and a connection process

2. 1 Device constitution

Device constitution when you use MS38D2-64H is shown in Fig.2.1.

Fig2.1 Device constitution

Main body	ROM type	Unit	Cable
EFP- I /1M	QzROM	EF1SRP-05U	—
	Flash	EF1SRP-01U	EF1TGCB-B(4-wire target connection cable)(separate sale) Power Supply cable for J3
EFP-S2/S2V	QzROM	EF1SRP-05U+ EF1CNT-96P *1	—
	Flash	EF1SRP-01U+ EF1CNT-96P *1	EF1TGCB-B(4-wire target connection cable)(separate sale)
	Flash/QzROM	EF1SRP-01US2	
EFP-RC	Flash/QzROM	EFXQZP-01-C(separate sale)	EF1TGCB-B(4-wire target connection cable)(separate sale)

*1) when you use EF1SRP-05U in EFP-S2/S2V, EF1CNT-96P (separate sale) is necessary.

2. 2 Connection Process

(1) In the case of QzROM

In case EF1SRP-05U is used, please connect it to EF1SRP-05U as shown in Fig.2.1.

In case EF1SRP-01US2 is connected, please use 4-wire target connection cable as shown in Fig 2.2. In case EFP-RC is connected, please use EFXQZP-01-C(separate sale) and EF1TGCB-B (4-wire target connection cable) as shown in Fig.2.3.

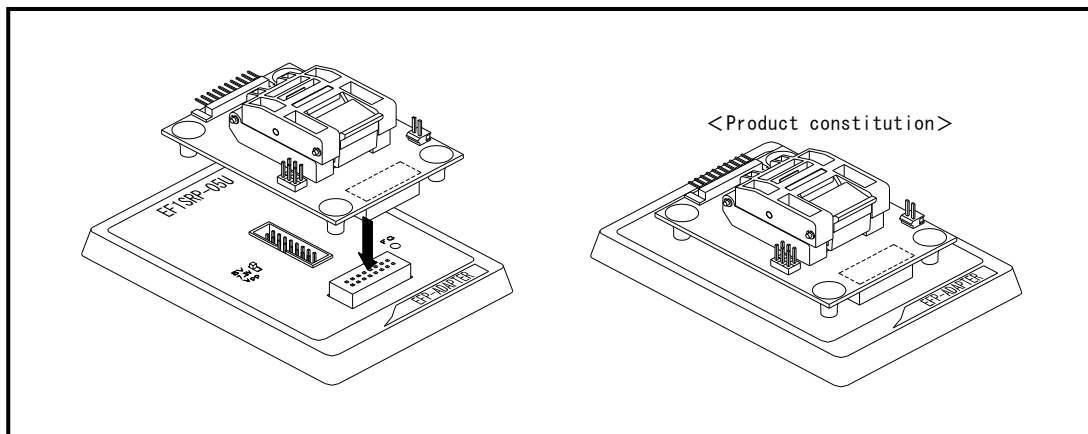

Fig 2.1 Connection with EF1SRP-05U

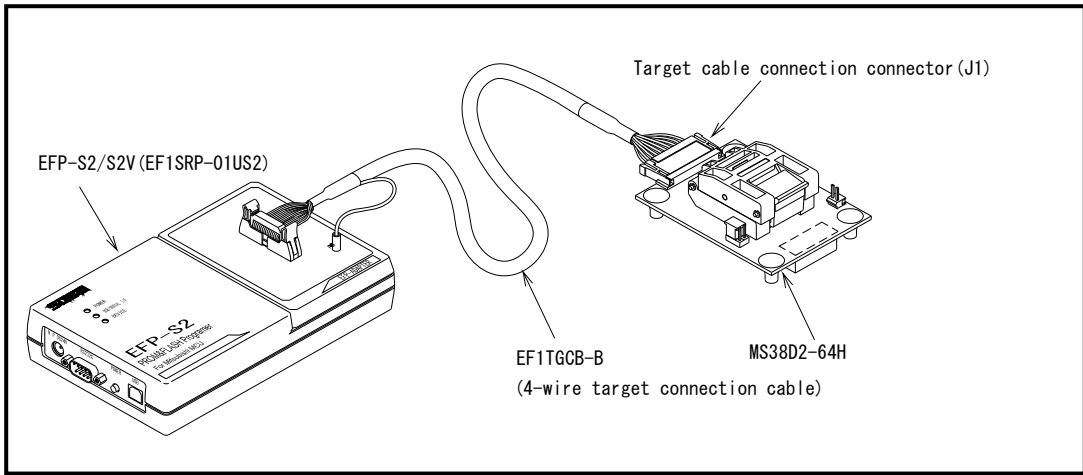

Fig 2.2 Connection with EF1SRP-01US2

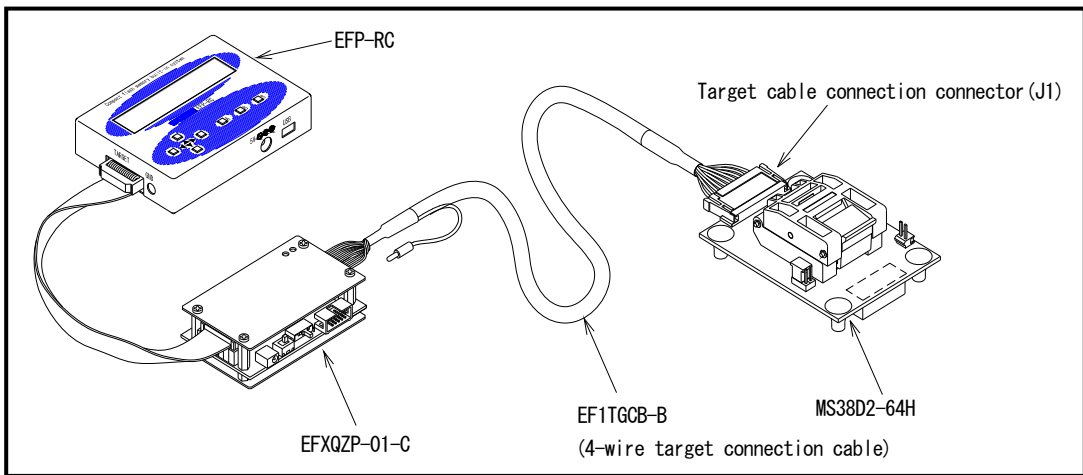

Fig 2.3 Connection with EFP-RC

(2) In the case of Flash

In case EF1SRP-01U or EF1SRP-01US2 is used, please connect it to EF1TGCB-B (4-wire target connection cable) as shown in Fig.2.4. Fig2.5.

In case EFP-RC is connected, please use EFXQZP-01-C(separate sale) and EF1TGCB-B (4-wire target connection cable) as shown in Fig.2.6.

Attention of the using of the MCU in Flash

< EFP-I/1M >

When you use EFP-I/1M, please connect a power supply cable to J3 of MS38D5-80H.

It does not output VDD to MS38D2-64H from EFP-I/1M.

Please input **VDD: 5V** from J3 power supply cable.

< EFP-S2/S2V >

The connection of the J3 power supply cable is unnecessary to output VDD: 5V from EFP-S2/S2V to MS38D2-64H.

< EFP-RC >

The connection of the J3 power supply cable is unnecessary to output VDD: 5V from MS38D2-64H to EFXQZP-01-C.

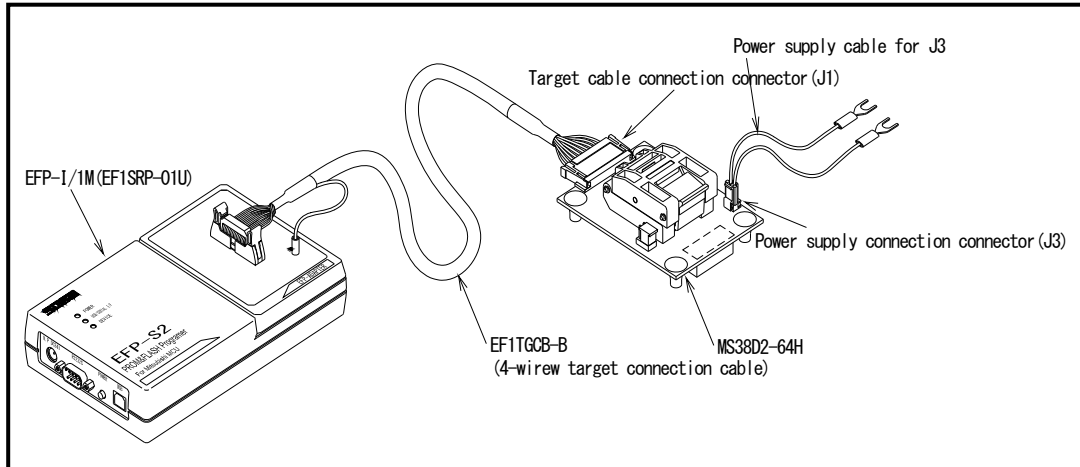

Fig 2.4 Connection with EFP-I/1M

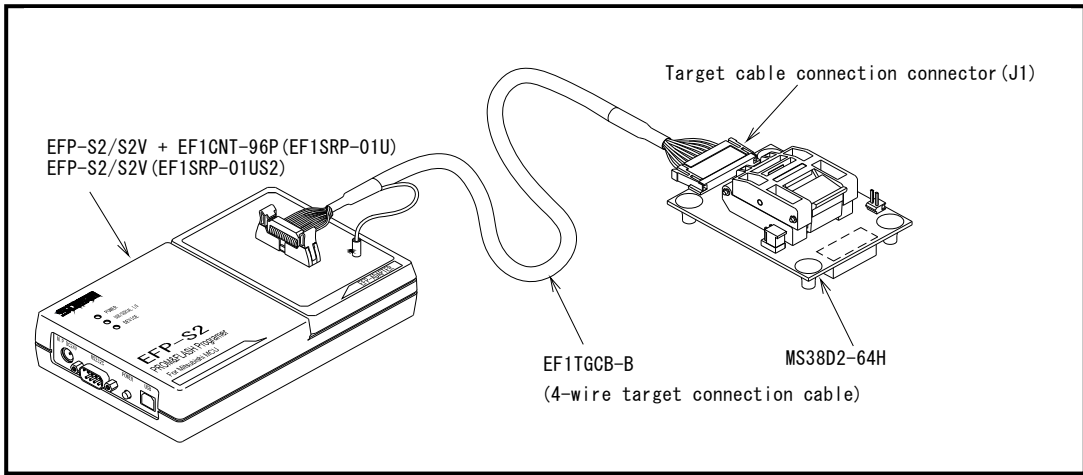

Fig 2.5 Connection with EFP-S2/S2V

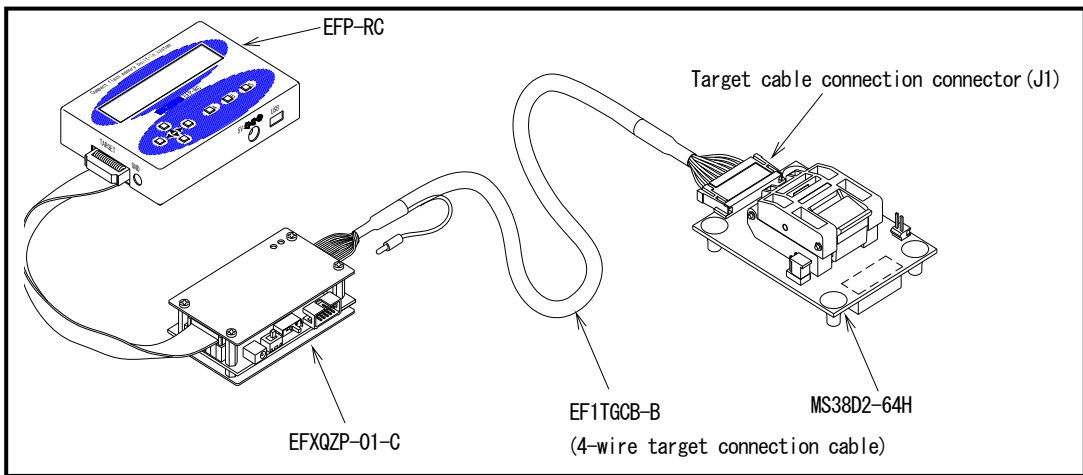

Fig 2.6 Connection with EFP-RC



3. List of Corresponding MCU and corresponding version

3. 1 List of Corresponding MCU

A corresponding MCU list for EFP-I/EFP-1M and EFP-S2/S2V of MS38D2-64H is shown in Fig 3.1.



A corresponding MCU list for EFP-RC of MS38D2-64H is shown in Fig 3.12.

Fig 3.1 Corresponding MCU List for EFP-I/EFP-1M and EFP-S2/S2V

ROM type	Device type	Corresponding MCU name	Program memory area	EF1SRP-05U SW setting	Flash/QzROM switch setting
QzROM	M38D2xG4	M38D24G4HP	C080h~FFFDh	T_VPP : 7.9V side *1	
	M38D2xG6	M38D24G6HP	A080h~FFFDh		
	M38D2xG8/M38D5xG8	M38D28G8HP	8080h~FFFDh		
	M38D2xGC/M38D5xGC	M38D29GCHP	4080h~FFFDh		
	M38D2xGF/M38D5xGF	M38D29GFHP	1080h~FFFDh		
Flash	M38D2xFF/M38D5xFF (MS Series)	M38D29FFHP	1000h~FFFFh	—	

*1) SW setting is necessary when you use EF1SRP-05U.

Fig3.2 Corresponding MCU List for EFP-RC

ROM type	Device type	Corresponding MCU name	Program memory area	EFXQZP-01-C SW setting	Flash/QzROM switch setting
QzROM	17: 38Dx QzROM 8Byte	M38D24G4HP	C080h~FFFDh	VDD : 5.0V side VPP : 7.9V side	
		M38D24G6HP	A080h~FFFDh		
		M38D28G8HP	8080h~FFFDh		
		M38D29GCHP	4080h~FFFDh		
		M38D29GFHP	1080h~FFFDh		
Flash	8: M38000 N.D.	M38D29FFHP	1000h~FFFFh	VDD : 5.0V side VPP : 5.0V side	

Attention of the choosing device type

Please use it by the combination mentioned above by all means.

When it uses it by a wrong combination, it may cause the problems like "it cannot write" "abnormality electric current drifts".

3. 2 About Software version (S/W)

The version numbers such as EFP-1 and WinEFP are displayed by [Help]→[About] in the WinEFP window menu. Please download the latest version up data on the following site when the S/W version such as EFP- I used is old.

< EFP- I S/W the latest free download site >

http://www.suisei.co.jp/download_e/productdata_efp1_e.html

< EFP-S2 S/W the latest free download site >

http://www.suisei.co.jp/download_e/productdata_s2_e.html

< EFP-S2V S/W the latest free download site >

http://www.suisei.co.jp/download_e/productdata_s2_e.html

Note on Corresponding Versions

Above corresponding versions might change without notice on account of the future capability improvement, etc. Furthermore in case the upgrade procedure manual is attached when this product is purchased, please refer to that manual as a priority.

4. Insertion Direction of MCU and cleaning of IC socket

4. 1 Insertion Direction of MCU

When MCU is inserted, No.1 pin of the IC socket on MS38D2-64H and MCU's No.1 pin should be connected. The Wrong insertion would cause a serious breakage of MCU.

Insertion direction of MCU is shown in Fig 4.1.

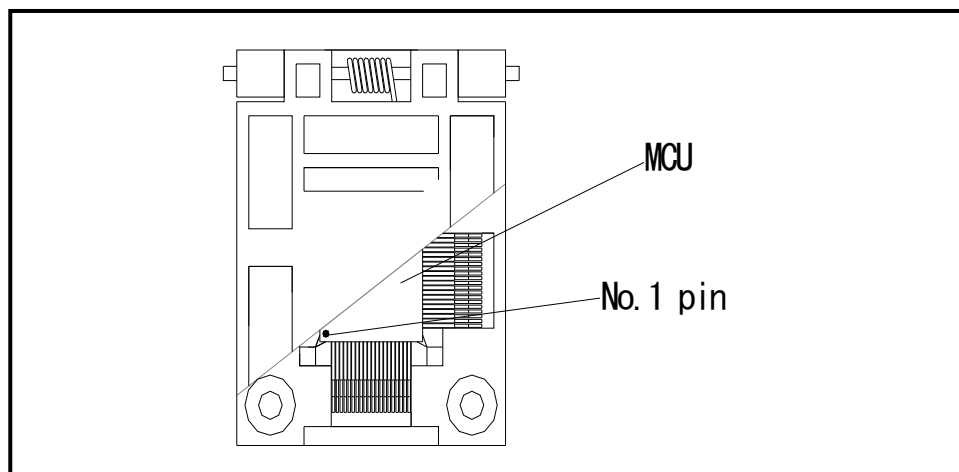

Fig 4.1 Insertion Direction of MCU

4. 2 Cleaning of IC Socket

A contact pin inside of the IC socket of the MCU unit might deteriorate and a contact failure might occur because of the number of times used and its age of service. As the contact failure may cause incorrect writing of MCU and malfunction of the writer, please take the below measures.

Measures against IC Socket Contact Failure

- (i) Please clean the contact pin surface inside of IC socket with a brush, etc. regularly, depending on the number of times used.
- (ii) If the product is not to be used for a long period, please keep it with less humidity in a plastic bag, etc.

Though enquiries on contact failures can be made, we regard IC sockets as consumable supplies. We may recommend you to replace them if a contact failure of IC socket occurs due to its use deterioration.

【Recommended item for cleaning】

About the cleaning of the contact pin in the IC socket, we recommend the use of the nanotech brush (Kita Mfg Co., Ltd).

The nanotech brush can remove the dirt which stuck to a contact pin, a very small amount of metastasis of solder. When a contact poor problem occurred, please try it.

About nanotech brush, please ask us or Kita Mfg Co., Ltd (refer to the following site).

Nanotech brush (Kita Mfg Co., Ltd.) http://www.kita-mfg.com/pro_nanotech_e.html

5. List of Pin Connection

Connector terminal names of target cable connection connector (J1) of MS38D2-64H are shown in List 5.1. Connector terminal names of power supply cable connection connector (J3) of MS38D2-64H are shown in list 5.2.

List 5.1 Connector terminal names of target cable connection connector (J1)

Pin No.	Terminal name	I/O(writer side)	PIN No.	Terminal name	I/O(writer side)
1	GND	—	6	SCLK	Out
2	RXD	In	7	TXD	Out
3	BUSY	In	8	PGM/OE	Out
4	VPP	Out	9	RESET	Out
5	VDD	Out	10	GND	—

List.5.2 Connector terminal names of power supply cable connection connector (J3)

Pin No.	Terminal name	PIN No.	Terminal name
1	VDD	2	GND