

MS4556-42E Users guide

Suisei Electronics System Co., Ltd
2nd Edition Issued June 2011

1. General Description

MS4556-42E is a writing target board for serial I/O mode used by connecting to EFP-I/1M (EF1SRP-05U) or EFP-S2/S2V.

Reading and writing data to microcomputer 4500 series with built-in Renesas Electronics 4 bit PROM is enabled by using MS4556-42E.

<Packing contents>

- 1) MS4556-42E
- 2) Users guide (this manual)

External Figure of MS4556-42E is shown in Fig 1.1.

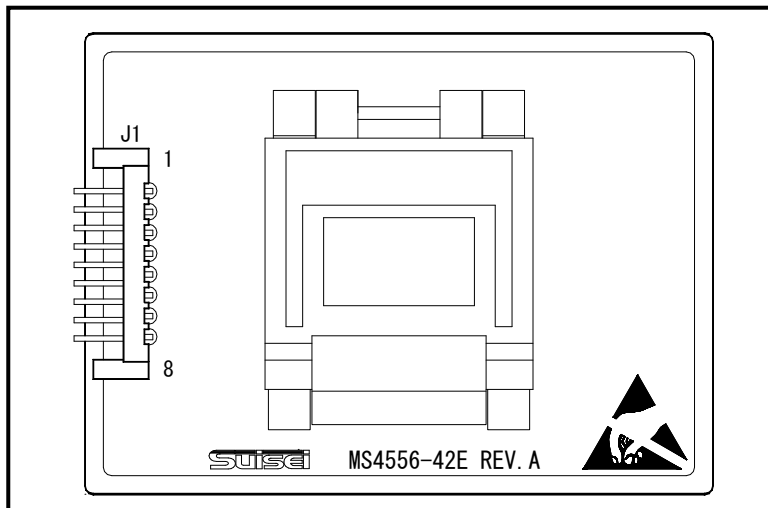

Fig 1.1 MS4556-42E External Figure

2. Device constitution and a connection method

2.1 Device constitution

Device constitution when you use MS4556-42E is shown in Fig.2.1.

Fig2.1 Device constitution

Main body	Unit	Cable
EFP-I/1M	EF1SRP-05U	EF1TGCB-A(3-wire target connection cable) (separate sale)
EFP-S2/S2V	EF1SRP-05U + EF1CNT-96P *1	
	EF1SRP-01US2	

*1) when you use EF1SRP-05U in EFP-S2/S2V, EF1CNT-96P (separate sale) is necessary.

2.2 Connection Process

In case MS4556-42E is connected, please use EF1TGCB-A (3-wire target connection cable) as shown in Fig.2.1.

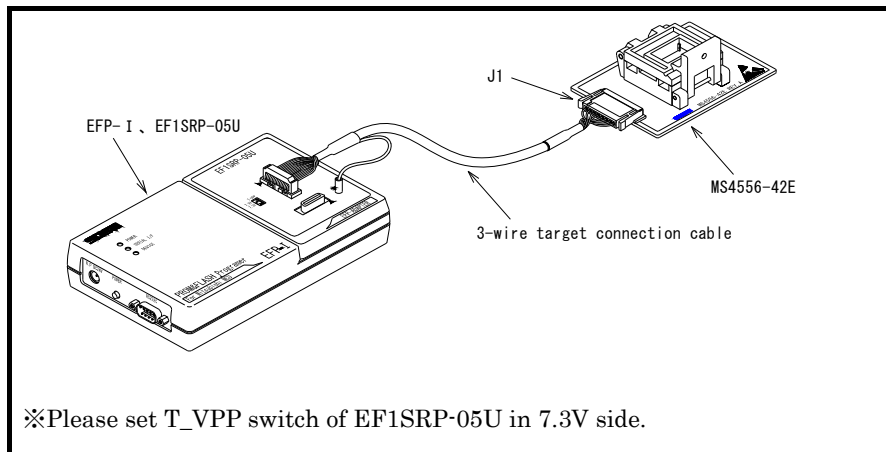

Fig.2.1 Connection with EF1TGCB-A (3-Wire Target Connection Cable)

3. List of Corresponding MCU and corresponding version

3.1 Corresponding MCU

A corresponding MCU list of MS4556-42E is shown in Fig.3.1.

Fig3.1 List of Corresponding MCU

Main body	Device type	Corresponding MCU name	Program memory area	EF1SRP-05U SW setting
EFP-I/1M	M3455xG8	M34556G8FPP	0h~1FFFh	T_VPP : 7.3V side*1
EFP-S2/S2V	VPP:7.3V	M34556G8HFP		

3.2 About Software version(S/W)

Please download the latest version up data on the following site when the S/W version.

Please use S/W of the latest version and confirm S/W version regularly.

【S/W version confirmation method】

The version numbers are displayed by [Help]→[About] in the WinEFP or WinEFP2 window menu.

< EFP-I/1M S/W the latest free download site >

http://www.suisei.co.jp/download_e/productdata_efp1_e.html

< EFP-S2 S/W the latest free download site >

http://www.suisei.co.jp/download_e/productdata_s2_e.html

< EFP-S2V S/W the latest free download site >

http://www.suisei.co.jp/download_e/productdata_s2_e.html

Note on Corresponding Versions

Above corresponding versions might change without notice on account of the future capability improvement, etc. Furthermore in case the upgrade procedure manual is attached when this product is purchased, please refer to that manual as a priority.

4. Insertion Direction of MCU and cleaning of IC socket

4.1 Insertion Direction of MCU

When MCU is inserted, No.1 pin of the IC socket on MS4556-42E and MCU's No.1 pin should be connected. The Wrong insertion would cause a serious breakage of MCU.

Insertion direction of MCU is shown in エラー! 参照元が見つかりません。 .

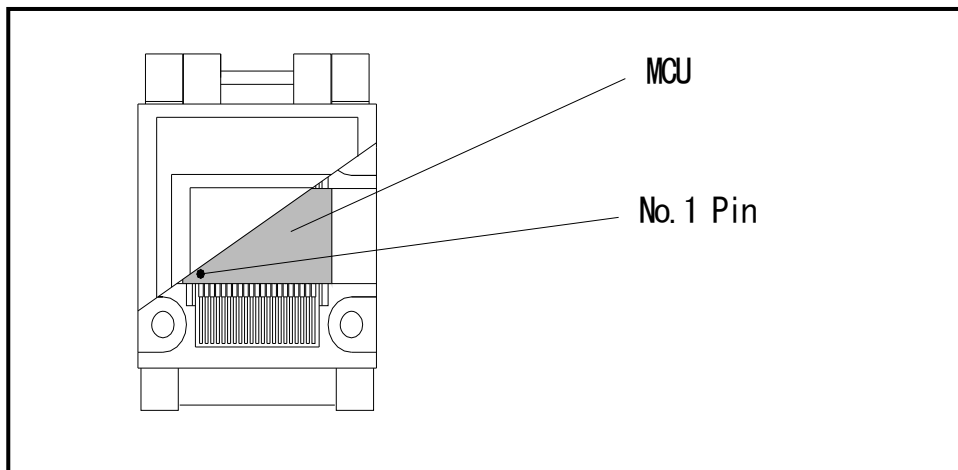

Fig.4.1 Insertion Direction of MCU

4.2 Cleaning of IC Socket

A contact pin inside of the IC socket of the MCU unit might deteriorate and a contact failure might occur because of the number of times used and its age of service. As the contact failure may cause incorrect writing of MCU and malfunction of the writer, please take the below measures.

Though enquiries on contact failures can be made, we regard IC sockets as consumable supplies. We may recommend you to replace them if a contact failure of IC socket occurs due to its use deterioration.

Measures against IC Socket Contact Failure

- (i) Please clean the contact pin surface inside of IC socket with a brush, etc. regularly, depending on the number of times used.
- (ii) If the product is not to be used for a long period, please keep it with less humidity in a plastic bag, etc.

【Recommended item for cleaning】

About the cleaning of the contact pin in the IC socket, we recommend the use of the nanotech brush (Kita Mfg Co., Ltd).

The nanotech brush can remove the dirt which stuck to a contact pin, a very small amount of metastasis of solder. When a contact poor problem occurred, please try it.

About nanotech brush, please ask us or Kita Mfg Co., Ltd (refer to the following site).

Nanotech brush (Kita Mfg Co., Ltd.) http://www.kita-mfg.com/pro_nanotech_e.html

5. List of Pin Connection

Connector terminal names target cable connection connector of MS4556-42E is shown in List 5.1.

List 5.1 Terminal List of target connection connector (J1, J2)

Pin No.	Terminal Name	I/O(writer side)	Pin No.	Terminal Name	I/O(writer side)
1	B U S Y	Input	5	S D A	I/O
2	V P P	Output	6	P G M / O E	Output
3	V D D	Output	7	R E S E T	Output
4	S C L K	Output	8	G N D	—